

**A heavy-duty system for P&F conveyors. Reduces labor and saves money by cutting downtime and protecting conveyor components.**

### Features/Benefits

- The OP-314 system lubricates sealed load wheels while the conveyor is running under normal conditions
- Reduces downtime and manual labor operations in lubricating free trolley load wheels
- Wheels that are lubricated properly can extend the life of conveyor components
- Eliminates surging and drag caused by non-lubricated wheels, so product can be spaced closer, increasing productivity
- Conveyor runs smoother, keeps product from swaying, reducing possibility of injury on the line
- Helps to reduce drive power requirements
- Less waste and contamination. A metered amount of lubricant is cleanly and precisely injected into each wheel
- The right lubrication system results in a clean operation – and saves you substantial amounts of time, work and money
- For overhead or inverted conveyors

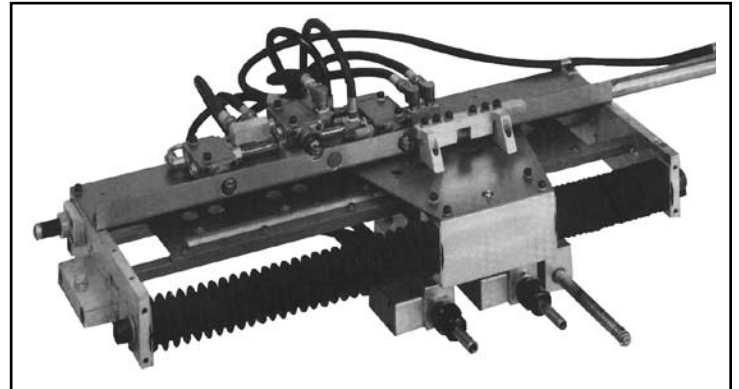

### SPECIFICATIONS

<b>Lubricant</b>	Oil: 22 cST@40°C and higher; Grease up to and including NLGI No. 2. Lubricants with solid additives must be colloidal < 5 Microns
<b>Shot Volume</b>	0.025 cu.in. (0.41 cm <sup>3</sup> ) per coupler
<b>Lubricant Pump</b>	Pneumatic 50:1 lubricant supply cover pump w/cover and follower plate for 5 gal, standard; 16 gal, optional; or 55 gal, optional
<b>Input Power</b>	110 VAC, 60Hz, standard; 110 VAC, 50Hz, optional; 220 VAC, 60Hz, optional; 220 VAC, 50Hz, optional; 24 VDC, optional
<b>Plant Air Pressure Required</b>	80 psi (6 bar), minimum
<b>Ambient Temperature</b>	60°F to 120°F (15°C to 50°C)
<b>Dimensions</b>	Envelope size, 60in L x 48in W x 48in H (152 cm L x 122 cm W x 122 cm H) from bottom of hoses to top of open control enclosure
<b>Shipping Weight</b>	350 lbs (158.9 kgs)
<b>Conveyor Speed</b>	Nominal range, 10 to 60 ft/min (3 to 18 meters/min), range may vary depending on wheel diameter and trolley spacing, consult OPCO for details

## OP-314 Assemblies

The OP-314 system consists of a controls assembly, two trolley lubricating assemblies—right and left-hand—and a lubricant supply pump assembly.

**Controls Assembly** – lubricant filter, pressure regulator, airline filter/regulator and electrical control system.

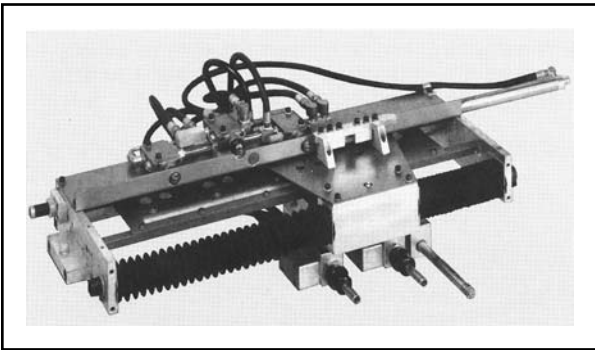

**Trolley Assemblies** – lubricant injector (coupler), load wheel locator, and controls to synchronize lubricator operation with conveyor movement.

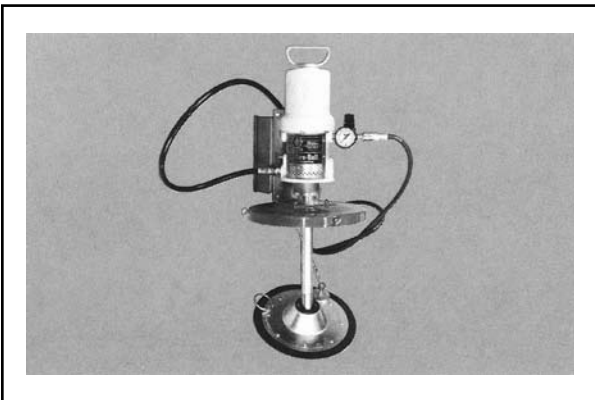

**Pump Assembly** – 50:1 pneumatically operated pump, container cover and follower plate, air inlet and grease outlet, and lube supply fault assembly.

## OP-314 System Operation

The OP-314 system is designed to lubricate free trolley sealed load wheels. The system injects a metered amount of lubricant into the wheel bearings, without interrupting manufacturing schedules. The system will dispense grease or oil. Lubricant is supplied to the unit by a pump which may be placed at floor level for added convenience.

Lubrication takes place during normal conveyor operation. Duration of the lube cycle can be manually controlled or electrically controlled by a timer, an electronic counter, or other electrical control. Trolleys can be unevenly spaced.

## Standard Components

- Two automatic lube head assemblies—one for each side, and each with two couplers, to lubricate four wheels simultaneously
- Airline preparation equipment—airline filter/regulator with gauge
- Lubricant supply pump—pneumatic 50:1 lubricant supply pump with cover and follower plate for 35# (5 gal.) pail
- Lubricant filter—with removable element for cleaning or replacement
- Protective bellows—protect areas subject to increased wear due to contamination by abrasive materials in the atmosphere
- Lube supply fault indicator, output contact and shut-off circuit

## Optional Equipment

- ChainMaster Lubricator Controller for precise lube cycle frequency control
- 12-hour timer for manual-on and automatic-off operation. System shuts off automatically at the end of the lube cycle
- 1000-hour fully automatic high-resolution repeat cycle timer
- PC interface relay and 3-position switch
- Additional mounting frames – complete with controls. Available for additional conveyors that are the same size. Trolley assemblies can be moved from one conveyor to another for portable convenience

### OP-314 Sequence of Operation

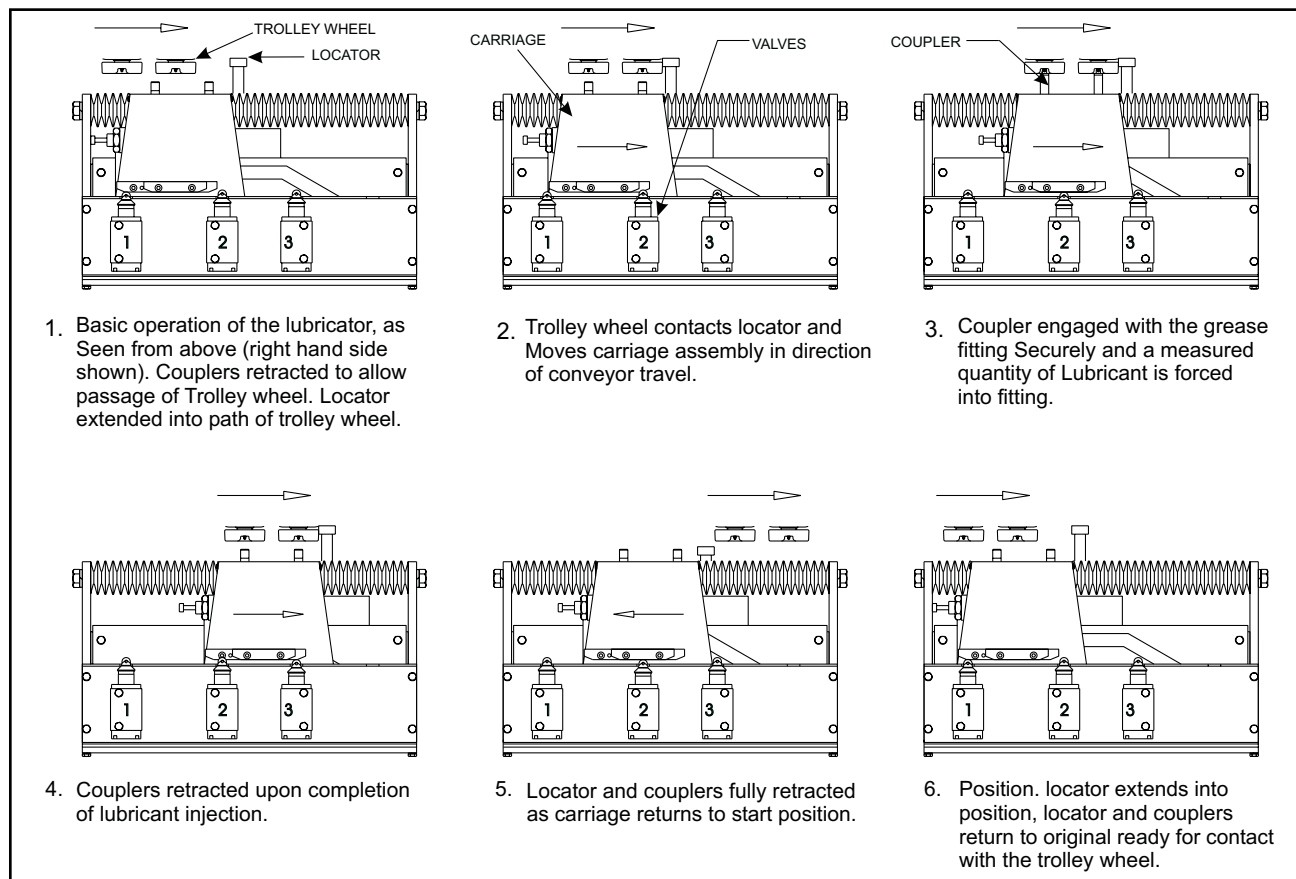

### Technical Assistance

Customized Technical Assistance Programs are available.

### Warranty

A limited warranty is provided with each OP-314 lubricator.

### WearMaster Lubricants – Specially Designed for Conveyor System Lubrication

OPCO has a complete line of Conveyor lubricants, for all conveyor applications, designed to keep you system running smoothly. Using the right lubricant for the application can save money otherwise lost to wear, increased power consumption, and unscheduled downtime.

Recognized worldwide as lubrication systems specialists, we have years of experience in every aspect of conveyor lubrication - from equipment design, sales and installation to lubricant sales, systems service, consultation and custom problem-solving. As a result, we're familiar with your needs and concerns. We can supply you with the WearMaster lubricants that will provide the best results in your conveyor system.