



OP-311 Outboard OP-331 Inboard Wheel Lubrication

A heavy-duty system for roller chain, flat top, gull wing and coil conveyors. Reduces labor and saves money by cutting downtime and protecting conveyor components.

Features/Benefits

- The OP-311/OP-331 system lubricates outboard/ inboard wheels while the conveyor is running under normal conditions
- Reduces downtime and manual labor operations in lubricating outboard/inboard wheels
- Wheels that are lubricated properly can extend the life of conveyor components
- Eliminates surging and drag caused by non-lubricated and worn wheels
- Conveyor runs more smoothly
- Helps to reduce drive power requirements
- Less waste. A metered amount of lubricant is cleanly and precisely injected into wheels
- The right lubrication system results in a clean operation — and saves you substantial amounts of time, work and money

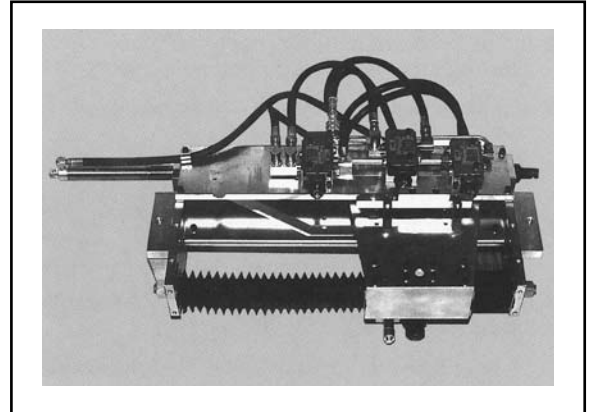

OP-311

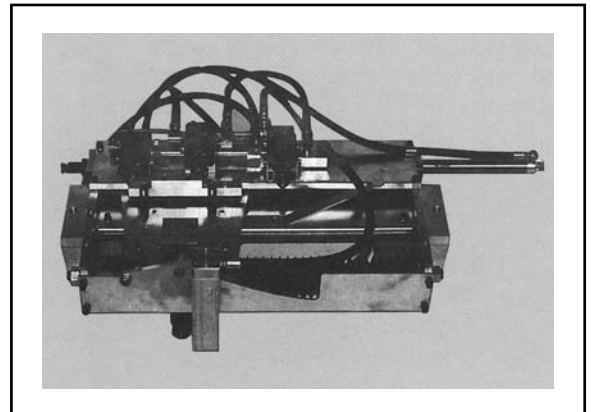

OP-331

SPECIFICATIONS	
Lubricant	Oil: 22 cST@40°C and higher; Grease up to and including NLGI No. 2. Lubricants with solid additives must be colloidal < 5 Microns
Shot Volume	0.025 cu.in. (0.41 cm ³) per coupler
Lubricant Pump	Pneumatic 50:1 lubricant supply cover pump w/cover and follower plate for 5 gal, standard; 16 gal, optional; or 55 gal, optional
Input Power	110 VAC, 60Hz, standard; 110 VAC, 50Hz, optional; 220 VAC, 60Hz, optional; 220 VAC, 50Hz, optional; 24 VDC, optional

Plant Air Pressure Required	80 psi (6 bar), minimum
Ambient Temperature	60°F to 120°F (15°C to 50°C)
Dimensions	Envelope size: 54in L x 60in W x 40in H from bottom of hoses to top of open control enclosure
Conveyor Speed	Nominal range, 10 to 45 ft/min, range may vary depending on wheel diameter, wheel spacing and conveyor speed, consult OPCO for details

OP-311/OP331 Assemblies

The OP-311/OP-331 systems consist of a controls assembly, two or four trolley assemblies and a lubricant supply pump assembly.

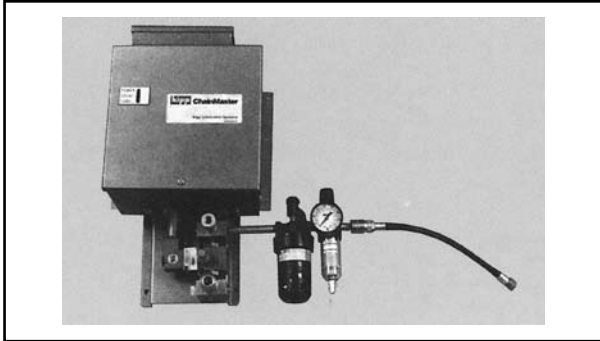

Controls Assembly – lubricant filter, pressure regulator, airline filter/regulator, and electrical control system.

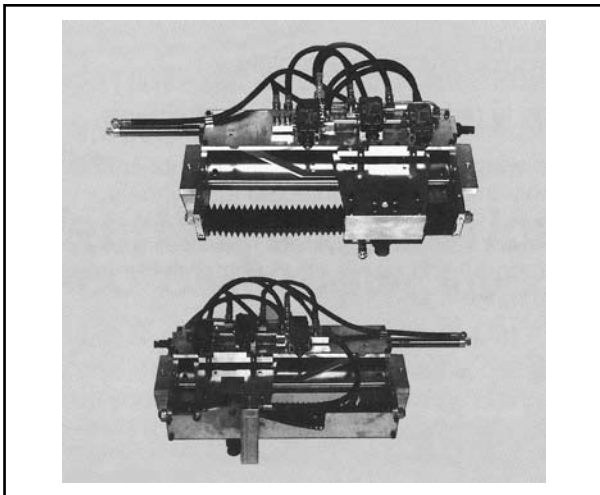

Trolley Assemblies – lubricant injector (coupler), wheel locator, and controls to synchronize lubricator operation with conveyor movement

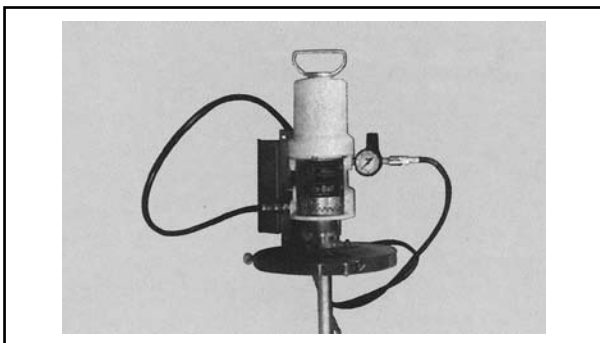

Pump Assembly – 50:1 pneumatically operated pump, container cover and follower plate, air inlet and grease outlet hoses, lube supply fault assembly and control regulator with gauge.

OP-311/OP331 Operation

The OP-311/OP-331 systems are designed to lubricate the wheels on material handling systems such as roller chains, flat top, gull wing and coil conveyors. The systems inject a metered amount of lubricant (grease or oil) into the wheel bearings, without interrupting manufacturing schedules. Lubricant is supplied to the unit by a pump, which may be placed at floor level for added convenience.

Lubrication takes place during normal conveyor operation. Duration and frequency of the lube cycle can be manually controlled or electrically controlled by a timer, or counter, or other electrical control.

Both systems can dispense lubricant through a fitting or open hole by means of a coupler assembly that travels with the conveyor.

Standard Components

- Two or four trolley assemblies for single or double strand conveyors
- Lubricant supply pump —pneumatic 50:1 lubricant supply pump with cover and follower plate for 35# (5 gal.) pail
- Pump mounted lube supply fault indicator, output contact and shut-off circuit
- Lubricant filter —with removable element for cleaning or replacement
- Protective bellows —to protect moving parts from dirt and moisture
- Airline preparation equipment —airline filter/regulator with gauge
- Template mounting for ease of installation

Optional Equipment

- 1000-hour repeat cycle timer with cycle progress display
- ChainMaster Lubricator Controller for precise lube cycle control
- 12-hour timer for manual-on and automatic-off operation. System shuts off automatically at the end of the lube cycle
- PC interface relay and 3-position switch

Sequence of Operation (OP-311 Outboard Wheel Lubrication Shown)

Illustrations simplified for clarity

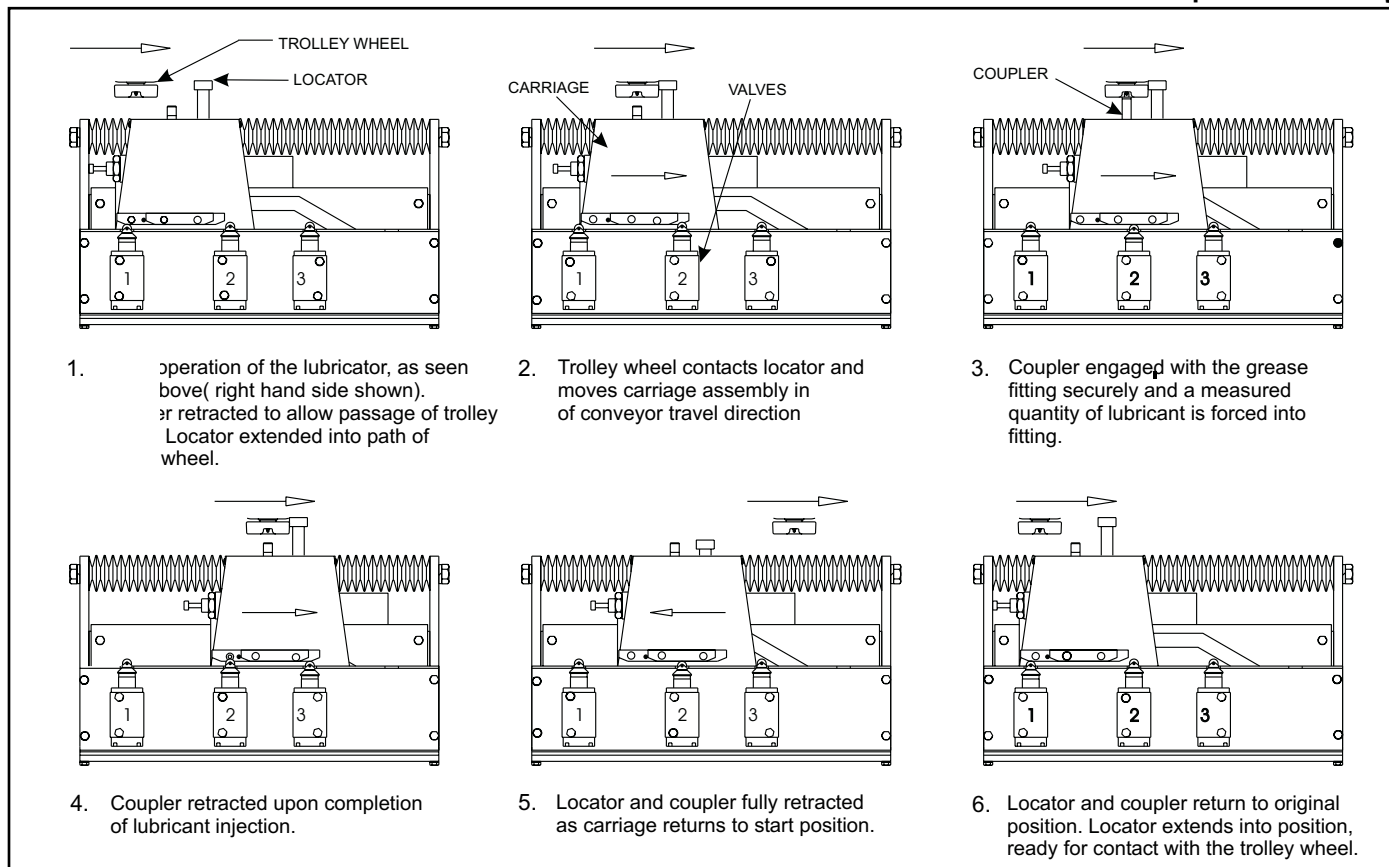

Technical Assistance

Customized Technical Assistance Programs are available.

Warranty

A Limited warranty is provided with each OP-311/ OP-331 lubrication system.

WearMaster Lubricants – Specially Designed for Conveyor System Lubrication

OPCO has a complete line of Conveyor lubricants for all conveyor applications, designed to keep your system running smoothly. Using the right lubricant for the application can save money otherwise lost to wear, increased power consumption, and unscheduled downtime.

Recognized worldwide as lubrication systems specialists, we have years of experience in every aspect of conveyor lubrication - from equipment design, sales and installation to lubricant sales, systems service, consultation and custom problem-solving. As a result, we're familiar with your needs and concerns. We can supply you with the WearMaster lubricants that will provide the best results in your conveyor system.